

TECHNICAL NOTE

Gary M. Vance,¹ John K. VanDyk,¹ B.A.; and Wayne A. Rowley,¹ Ph.D.

A Device for Sampling Aquatic Insects Associated with Carrion in Water

REFERENCE: Vance, G. M., VanDyk, J. K., and Rowley, W. A., "A Device for Sampling Aquatic Insects Associated with Carrion in Water," *Journal of Forensic Sciences*, JFSCA, Vol. 40, No. 3, May 1995, pp. 479-482.

ABSTRACT: A device that permits the sampling of aquatic insects associated with carcasses in water with minimal disturbance of the natural environment is described. A field study conducted in early summer documented strictly aquatic insects recovered from decaying pig carcasses in an Iowa freshwater lake using this sampling method. Forty carcasses of newborn pigs were placed in the devices and removed at two-day intervals to simulate a complete decomposition sequence. Twenty species of insects from twelve families in five orders were documented, along with water mites (Arachnida:Acari) and amphipods (Crustacea:Amphipoda).

KEYWORDS: forensic science, aquatic insects, carrion

Research involving forensic entomology has been largely limited to the terrestrial environment. Many terrestrial insect species useful during medicolegal investigations have been documented [1-6]. Aquatic insect species could also prove useful but have not received sufficient attention. Corpses are frequently found in aquatic habitats [7] and include suspected homicide victims [8]. Aquatic insects have not been used for determining submersion interval during these investigations [7], primarily because information on the role of insects in the decay process has not been available [9]. The information that is available is reviewed by Haskell et al. [7], who note that most studies have concentrated on blow flies and other strictly terrestrial species associated with carrion in water. In these few studies, little was done to show what aquatic fauna were attracted to such carrion. Haskell et al. [7] established the potential of several species of aquatic insects for determining submersion interval of a carcass in water but stated that, without further data, only generalizations could be made.

This situation greatly hinders the application of forensic entomology to investigations involving aquatic areas. We describe a novel technique of documenting the strictly aquatic fauna associated with carrion in a natural body of fresh water. Further studies using this method will increase our knowledge in an area that could prove beneficial.

Journal Paper No. J-15884 of the Iowa Agriculture and Home Economics Experiment Station, Ames, Project 3170.

¹Laboratory Assistant, Predoctoral Research Associate, and Professor, respectively, Department of Entomology, Iowa State University, Ames, IA.

Methods

Two plots of similar substrate, water depth, and plant communities were chosen in a 12-ha (30-acre) lake. The substrate in each plot consisted of a mud bottom with no visible vegetation or dead brush. Water depth ranged from 0.6 to 1.4 m and averaged 1.2 m throughout the study. Both plots were large enough to contain 25 suspension frames each with a minimum intermittent distance of 3 m to prevent disturbance of neighboring units during individual carcass removals. Plot A and plot B were separated by a distance of 15 m. The units were placed 8-9 m from shore to ensure adequate water depth throughout the study.

Suspension frames with baskets were used to hold the carcasses during decomposition. Frames consisted of a base and an L-shaped arm from which the basket was suspended. The base, constructed of 61-cm section of 5 × 10 cm (2 × 4 in.) pine, surrounded a central, upright 152-cm section. On top of this central support was attached an arm that extended 61 cm toward the basket and 30.5 cm away from the basket. The arm was stabilized on the side opposite the basket by a 46-cm section of 5 × 5 cm pine attached diagonally to the upright 152-cm section. The entire structure was stabilized by a concrete block which rested on the base and surrounded the upright section.

Each frame (Fig. 1) supported a 60 × 38 cm wire basket made of 2.54-cm (1-in.) poultry netting looped lengthwise into a cylinder by joining the ends. The ends of the netting were folded in to close the ends of the cylinder laterally. The holes of the netting were sufficiently large to allow insect fauna complete access to carcasses. Each basket was suspended from the frame's arm by a 0.48 cm (³/₁₆ in.) diameter nylon rope running through a screw eye, which enabled easy adjustment of the basket depth. The opposing end of the rope was tied to a brick and anchored to the bottom.

Suspension frames and baskets were placed in the lake five days before carcasses were added to allow time for disturbance effects to subside.

To document insects associated with the decay process without disrupting the natural succession of insects on the carcass, the complete decay of one carcass was simulated by compiling data from many carcasses. Controls consisted of the suspension frame and basket without a carcass and were sampled in the same manner as the other baskets.

Forty young pigs, stillborn or killed shortly after birth by asphyxiation by the mother, were used as subjects for this study. Upon death, pigs were placed on ice for up to 20 h until they could be

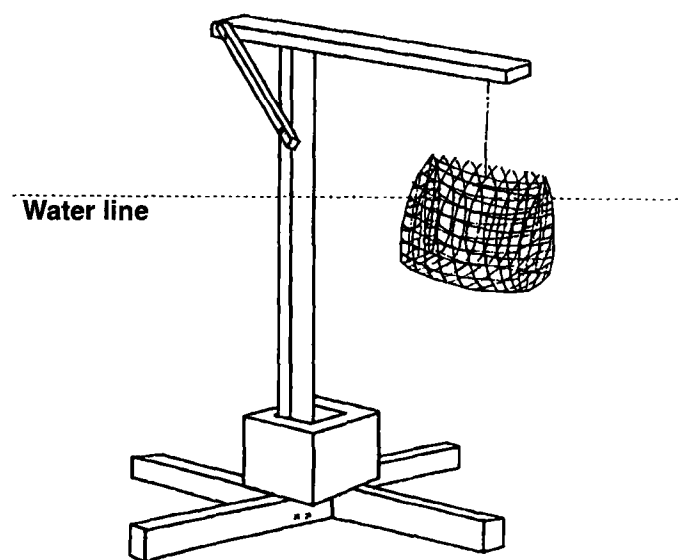

FIG. 1—Holding unit design (rope and screw eye for height adjustment of basket not shown).

wrapped in plastic and transferred to a freezer where they were stored for two to three months. Pigs averaged 1.27 ± 0.06 kg. Two days preceding each submersion date, the pigs were removed from the freezer and stored in refrigeration to thaw; carcasses were completely thawed by the time they were placed into the water.

The number of carcasses used was based on information provided by Payne and King [3] in which a pig carcass was shown to last less than or equal to 20 days in summer during temperatures similar to those predicted for our area. With 40 carcasses, two carcasses could be removed from each plot during sampling days and result in representation of a complete decay cycle in each plot.

Within each plot, all pigs and control baskets were submerged at the same time. In plot A, submersion took place on 12 June 1993; in plot B, submersion took place on 18 June 1993. Two carcasses were chosen randomly and were removed from each plot at two-day intervals and examined for invertebrates. Controls were removed and examined at four-day intervals. All pigs in plot B were matched to pigs in plot A by weight, so that pigs of the same weight were removed after the same time of exposure. The removal schedule is shown in Table 1.

TABLE 1—Removal schedule of pig carcasses.

	Plot A	Plot B
12 June	Submersion	
14 June	Two carcasses & control	
16 June	Two carcasses	
18 June	Two carcasses & control	Submersion
20 June	No removal ^a	No removal ^a
22 June	Two carcasses & control	Two carcasses
24 June	Two carcasses	Two carcasses & control
26 June	Two carcasses & control	Two carcasses
28 June	Two carcasses	Two carcasses & control
30 June	Two carcasses & control	Two carcasses
2 July	Two carcasses	Two carcasses & control
4 July		Two carcasses
6 July		Two carcasses & control
8 July		Two carcasses

^aRemoval was precluded by high water.

During submersion, each pig was placed in its assigned basket with approximately 25 cm of carcass below the surface and 5 cm above to allow access to the surface within the baskets as the carcasses decayed. This placed the pigs approximately 0.6 m to 1.2 m above the lake bottom.

Carcasses were retrieved by moving very slowly through the water to within 2.5 m of the suspension frame, then bringing a large fine-mesh net up from below to surround the entire wire basket and contents. The net was built from a 182.9 cm (6 ft) section of 8 cm ($\frac{5}{16}$ in.) fir, a 203.2 cm (80 in) diameter ring of #10 galvanized wire, and muslin cloth. The fabric component of the net was 70 cm (24 in.) tall with straight sides and the bottom was of 425 μ m (TE 35) mesh sized to the same diameter as the ring to easily accommodate the wire basket.

After being brought to shore, the basket containing the carcass was removed and placed in a white plastic tub. The net was thoroughly inspected with the aid of a magnifying glass until representatives of all visibly differing insects present were collected. After the net was thoroughly inspected, the wire basket was removed from around the carcass and searched. Finally, the carcass itself was searched by rinsing with distilled water.

A visual assessment of each carcass was made and recorded upon removal. Correlation between our findings and the six stages of decay described by Payne and King [3] was attempted.

Results

Representatives of the aquatic insects found during each removal were collected and resulted in documentation of twelve insect families from five orders. These insects are listed in Table 2 along with two noninsects that were also recovered from the carcasses. Noninsects were water mites (Arachnida:Acari) and amphipods (Crustacea:Amphipoda).

Control baskets yielded five families from three orders. Insects occurring on both carcasses and control baskets were four mayfly larvae (Ephemeroptera), a damselfly larva (Odonota) and chironomids (Diptera). Both noninsect invertebrates were also found on control baskets.

Many of the insects listed were collected only once. Insects collected more than three times were chironomids (30 collections) and mayflies (20 collections), especially larval *Caenis latipennis* Banks (nine collections) and *Baetis intercalaris* McDunnough (four collections). Amphipods were present in 19 collections, and water mites were in nine collections.

The submerged fresh stage lasted through day 2. Unlike Payne and King [3], who collected only hydrophilids during the fresh stage, we collected two species of mayflies (*Baetis intercalaris* and *Caenis* sp.) and chironomid midges during the fresh stage. The second, or early floating stage ranged from day 2 to day 4. These two stages showed relatively no decomposition, although the second stage showed fluid-filled epidermal blisters, slight bloating, and an external coat of slime on the legs of the carcasses. The third, or floating decay stage ranged from day 4 to day 6. Pronounced decay like that observed by Payne and King [3] was documented, including advanced bloating, muscle flaccidity, ease of toenail detachment, and tears in the epidermis occasionally exposing parts of the skull and other internal areas. However, egg laying and larval feeding by Diptera were not observed. Only once during this stage was an egg mass located, and larval feeding by nonchironomid Diptera was not seen at all. Stages beyond the floating decay stage were so variable that categorization was impossible.

TABLE 2—Aquatic insects associated with pig carrion in a freshwater lake.

Order	Suborder	Family	Genus	Species	Stage
Ephemeroptera	Schistonota	Baetidae	<i>Baetis</i>	<i>propinguus</i> (Walsh)	L
Ephemeroptera ^a	Schistonota	Baetidae	<i>Baetis</i>	<i>intercalaris</i>	L
Ephemeroptera ^a	Schistonota	Baetidae	<i>Baetis</i>	McDunnough <i>flavistriga</i>	L
Ephemeroptera	Schistonota	Oligoneuriidae	<i>Isonychia</i>	<i>sp.</i>	L
Ephemeroptera ^a	Schistonota	Heptageniidae	<i>Heptagenia</i>	<i>diabasia</i> Burks	L
Ephemeroptera	Schistonota	Heptageniidae	<i>Heptagenia</i>	<i>flavescens</i> (Walsh)	L
Ephemeroptera ^a	Pannota	Caenidae	<i>Caenis</i>	<i>latipennis</i> Banks	L
Ephemeroptera	Pannota	Caenidae	<i>Caenis</i>	<i>sp.</i>	L
Odonata	Zygoptera	Calopterygidae	<i>Calopteryx</i>	<i>sp.</i>	L
Odonata ^a	Zygoptera	Coenagrionidae	<i>Zoniagrion</i>	<i>sp.</i>	L
Odonata	Zygoptera	Coenagrionidae	<i>Argia</i>	<i>sp.</i>	L
Hemiptera	Nepomorpha	Pleidae	<i>Neoplea</i>	<i>sp.</i>	A
Hemiptera	Nepomorpha	Corixidae	<i>Palmacorixa</i>	<i>sp.</i>	A
Hemiptera	Nepomorpha	Corixidae		<i>sp.</i>	L
Coleoptera	Polyphaga	Chrysomelidae		<i>sp.</i>	L
Coleoptera	Adephaga	Dytiscidae		<i>sp.</i>	L
Coleoptera	Adephaga	Dytiscidae		<i>sp.</i>	L
Coleoptera	Adephaga	Dytiscidae		<i>sp.</i>	A
Coleoptera	Adephaga	Halipilidae	<i>Peltodytes</i>	<i>sp.</i>	A
Diptera ^a	Nematocera	Chironomidae		<i>sp.</i>	L

^aDenotes presence in control baskets.

Discussion

The suspension frames used to contain the carcasses while they were in the water allowed quick retrieval of the carcasses in a way that prevented insects from escaping when a carcass was disturbed; also, these units protected the carcasses from vertebrate scavengers without interfering with the invertebrate fauna.

The holding-unit design allowed the carcass to float to the surface and sink below the surface as is natural during the decay process. Insects confined to the lake bottom were not documented during this study because access to the bottom was prevented by this design.

The retrieval process performed on all carcasses produced various terrestrial insect species associated with the decay process. Although these insects were outside the scope of this paper and were not recorded, further studies using this technique are not limited to strictly aquatic fauna.

The insects documented are not intended to represent an exhaustive list of insects that are attracted to carrion in water but, instead, represent only the beginning of such a list. Many insects that were never documented may have visited in short successional stages that could be documented in future studies by frequent carcass sampling.

During the collection process, water mites and mayflies were typically found while searching the net after a carcass was recovered. These detached readily during the first signs of carcass disturbance. The remaining insects were recovered coming off the carcass itself as the water drained from it into the tub.

Most chironomid midges were found between the carcass and a slimy film that developed on the surface of the carcass. Attachment by chironomids has been documented as occurring on human cadavers [8]. Chironomids were the most numerous of all insects collected. Occurrence had begun by day 2 and was established by day 4. A marked increase in the number of chironomids was noted upon the third retrieval—about four to six days after submersion. This increase may prove useful in forensic investigations if it is replicated in future studies involving carcasses in an aquatic environment.

Caddisflies (Trichoptera) can cause damage to corpses [10] and were discussed by Haskell et al. [7] as possible indicator species. No Trichoptera were found in this study, probably because the carcasses did not have access to the lake bottom.

Acknowledgments

The authors thank M. Siegrist for technical assistance; Dr. T. H. Klubertanz, Dr. K. H. Holscher and Dr. R. E. Lewis for specimen identification; and Dr. W. G. Hyde for facilities.

References

- [1] Mégnin, "La Faune des Cadavers, (The Fauna of Cadavers)," *Encyclopédie Scientifique des Aide-Memoire*, G. Masson, Gauthier-Villars et Fils, Paris, 1894.
- [2] Easton, A. M. and Smith, K. G. V., "The Entomology of the Cadaver," *Medicine Science and the Law*, Vol. 10, 1970, pp. 208–215.
- [3] Payne, J. A. and King, E. W., "Insect Succession and Decomposition of Pig Carcasses in Water," *Journal of Georgia Entomology Society*, Vol. 34, No. 3, 1972, pp. 153–162.
- [4] Rodriguez, W. C. and Bass, W. M., "Insect Activity and its Relationship to Decay Rates of Human Cadavers in East Tennessee," *Journal of Forensic Sciences*, Vol. 28, No. 2, 1983, pp. 423–432.
- [5] Goff, M. L. and Flynn, M. M., "Determination of Post-mortem Interval by Arthropod Succession: A Case Study from the Hawaiian Islands," *Journal of Forensic Sciences*, Vol. 36, No. 2, 1991, pp. 607–614.
- [6] Lord, W. D., Adkins, T. R., and Catts, E. P., "The Use of *Synthesomyia nudestria* (Van Der Wulp) and *Calliphora vicina* (Robineau-Desvoidy) to Estimate the Time of Death of A Body Buried Under a House," *Journal of Agriculture and Entomology*, Vol. 9, No. 4, 1992, pp. 227–235.
- [7] Haskell, N. H., McShaffrey, D. G., Hawley, D. A., Williams, R. E., and Pless, J. E., "Use of Aquatic Insects in Determining Submersion Interval," *Journal of Forensic Sciences*, Vol. 34, No. 3, 1989, pp. 622–632.
- [8] Hawley, D. A., Haskell, N. H., McShaffery, D. G., Williams, R. E., and Pless, J. E., "Identification of a 'Red Fiber': Chironomid Larvae," *Journal of Forensic Sciences*, Vol. 34, 1989, pp. 617–621.
- [9] Catts, E. P. and Haskell, N. H., *Entomology and Death (A Procedural Guide)*, Joyces Print Shop, Inc., Clemson, South Carolina, 1990, 182 pp.

[10] Holzer, F. J., "Zerstörung an Wasserleichen durch Larven des Köcherfliege," *Dtsch. Z. Gesamte Gerichtl. Med.*, Vol. 31, 1939, pp. 223-228.

Address requests for reprints or additional information to

Wayne A. Rowley, Ph.D.
Department of Entomology
Iowa State University
Ames, IA 50011-3222